

PRODUCT SPECIFICATION

Part No.:	AC-SFBL-35G1-10/AC-SFBL-53G1-10	
Description:	1.25G SFP Transceiver, BIDI TX1310nm/RX1550nm 10km 1.25G SFP Transceiver, BIDI TX1550nm/RX1310nm 10km	
Release Date	Rev.	Revision Change Description
2015/06/07	A0	New Release
2020/12/28	A1	Template Update
2021/03/02	A2	1550nm change from FP to DFB
2023/08/15	A2	1310nm Tx/Rx update from 1290-1310-1330 to 1260-1310-1360

Features

- ✧ Up to 1.25Gbps bi-directional data links
- ✧ 1310nm FP laser transmitter and PIN photo detector for AC-SFBL-35G1-10
- ✧ 1550nm DFB laser transmitter and PIN photo detector for AC-SFBL-53G1-10
- ✧ Compliant with SFP MSA and SFF-8472 with single LC receptacle
- ✧ Digital Diagnostic Monitoring: Internal Calibration or External Calibration
- ✧ Compatible with SONET
- ✧ Compatible with RoHS
- ✧ +3.3V single power supply
- ✧ Operating case temperature:
 - ✧ Standard : 0 to +70°C
 - ✧ Industrial : -40 to +85°C

Application

- ✧ SDH and SONET system
- ✧ Fiber Channel
- ✧ Switch to Switch interface
- ✧ Switched backplane applications
- ✧ Router/Server interface
- ✧ Other optical transmission systems

Standard

- ✧ Gigabit Ethernet
- ✧ Compliant with SFF-8472
- ✧ Switched Backplane Applications
- ✧ Router/Server Interface

Specification

Absolute Maximum Ratings

Parameter	Symbol	Min	Max	Unit
Supply Voltage	Vcc	0	4	V
Storage Temperature	Ts	-40	+85	°C
Operating Humidity	-	5	85	%

Recommended Operating Conditions

Parameter	Symbol	Min	Typical	Max	Unit	
Operating Case Temperature	Standard	Tc	0		+70	°C
	Industrial		-40		+85	°C
Power Supply Voltage	Vcc	3.13	3.3	3.47	V	
Power Supply Current	Icc			300	mA	
Data Rate			1.25		Gbps	

Optical and Electrical Characteristics

Parameter	Symbol	Min	Typical	Max	Unit	Notes
Transmitter						
Centre Wavelength	λ_c	1260	1310	1360	nm	AC-SFBL-35G1-10
		1530	1550	1570	nm	AC-SFBL-53G1-10
Spectral Width (RMS)	$\Delta\lambda$			1	nm	
Average Output Power	Pout	-9		-3	dBm	1
Extinction Ratio	ER	8			dB	
Optical Rise/Fall Time (20%~80%)	tr/tf			0.16	ns	
Data Input Swing Differential	V _{IN}	400		1800	mV	2
Input Differential Impedance	Z _{IN}	90	100	110	Ω	
TX Disable	Disable		2.0	Vcc	V	
	Enable		0	0.8	V	
TX Fault	Fault		2.0	Vcc	V	
	Normal		0	0.8	V	
Receiver						
Centre Wavelength	λ_c	1530	1550	1570	nm	AC-SFBL-35G1-10
		1260	1310	1360	nm	AC-SFBL-53G1-10
Receiver Sensitivity				-20	dBm	3

Receiver Overload		-3			dBm	3
LOS De-Assert	LOS _D			-24	dBm	
LOS Assert	LOS _A	-35			dBm	
LOS Hysteresis		1		4	dB	
Data Output Swing Differential	V _{out}	700		900	mV	4
LOS	High	2.0		V _{cc}	V	
	Low			0.8	V	

Notes:

1. The optical power is launched into SMF.
2. PECL input, internally AC-coupled and terminated.
3. Measured with a PRBS 2⁷-1 test pattern @1250Mbps, BER ≤1×10⁻¹².
4. Internally AC-coupled.

Timing and Electrical

Parameter	Symbol	Min	Typical	Max	Unit
Tx Disable Negate Time	t _{on}			1	ms
Tx Disable Assert Time	t _{off}			10	μs
Time To Initialize, including Reset of Tx Fault	t _{init}			300	ms
Tx Fault Assert Time	t _{fault}			100	μs
Tx Disable To Reset	t _{reset}	10			μs
LOS Assert Time	t _{loss_on}			100	μs
LOS De-assert Time	t _{loss_off}			100	μs
Serial ID Clock Rate	f _{serial_clock}			400	KHz
MOD_DEF (0:2)-High	V _H	2		V _{cc}	V
MOD_DEF (0:2)-Low	V _L			0.8	V

Digital Diagnostic Memory Map

The transceivers provide serial ID memory contents and diagnostic information about the present operating conditions by the 2-wire serial interface (SCL, SDA).

The diagnostic information with internal calibration or external calibration all are implemented, including received power monitoring, transmitted power monitoring, bias current monitoring, supply voltage monitoring and temperature monitoring.

The digital diagnostic memory map specific data field defines as following.

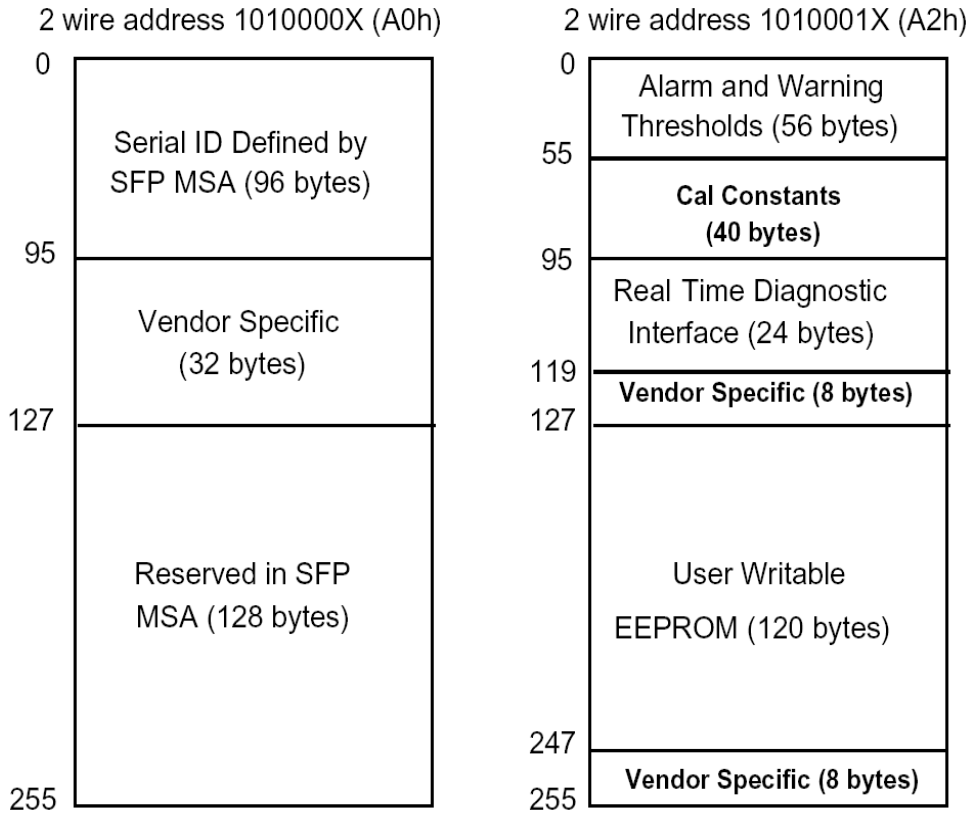

Pin Definitions

Pin Diagram

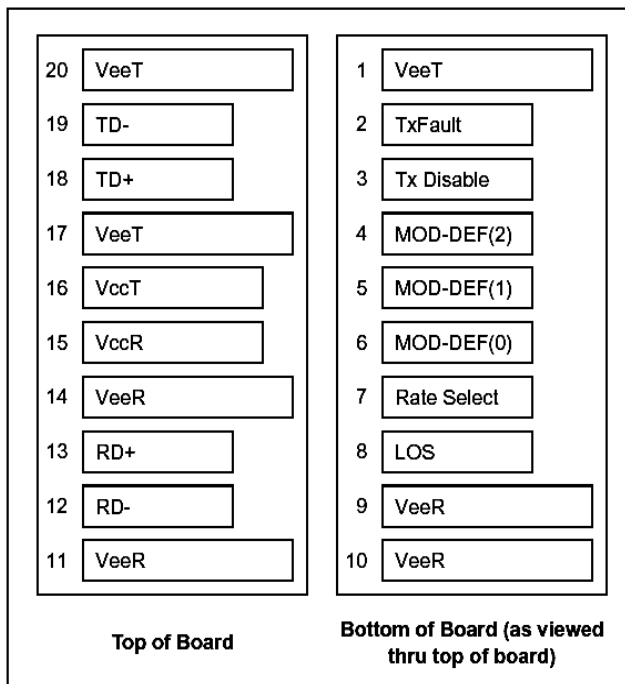

Pin Descriptions

Pin	Signal Name	Description	Plug Seq.	Notes
1	V _{EET}	Transmitter Ground	1	
2	TX FAULT	Transmitter Fault Indication	3	Note 1
3	TX DISABLE	Transmitter Disable	3	Note 2
4	MOD_DEF(2)	SDA Serial Data Signal	3	Note 3
5	MOD_DEF(1)	SCL Serial Clock Signal	3	Note 3
6	MOD_DEF(0)	TTL Low	3	Note 3
7	Rate Select	Not Connected	3	
8	LOS	Loss of Signal	3	Note 4
9	V _{EER}	Receiver ground	1	
10	V _{EER}	Receiver ground	1	
11	V _{EER}	Receiver ground	1	
12	RD-	Inv. Received Data Out	3	Note 5
13	RD+	Received Data Out	3	Note 5
14	V _{EER}	Receiver ground	1	
15	V _{CCR}	Receiver Power Supply	2	
16	V _{CCT}	Transmitter Power Supply	2	
17	V _{EET}	Transmitter Ground	1	
18	TD+	Transmit Data In	3	Note 6
19	TD-	Inv. Transmit Data In	3	Note 6
20	V _{EET}	Transmitter Ground	1	

Notes:

Plug Seq.: Pin engagement sequence during hot plugging.

- TX Fault is an open collector output, which should be pulled up with a 4.7k~10kΩ resistor on the host board to a voltage between 2.0V and V_{cc}+0.3V. Logic 0 indicates normal operation; Logic 1 indicates a laser fault of some kind. In the low state, the output will be pulled to less than 0.8V.
- TX Disable is an input that is used to shut down the transmitter optical output. It is pulled up within the module with a 4.7k~10kΩ resistor. Its states are:
 - Low (0 to 0.8V): Transmitter on
 - (>0.8V, < 2.0V): Undefined
 - High (2.0 to 3.465V): Transmitter Disabled
 - Open: Transmitter Disabled
- Mod-Def 0,1,2. These are the module definition pins. They should be pulled up with a 4.7k~10kΩ resistor on the host board. The pull-up voltage shall be V_{ccT} or V_{ccR}.
 - Mod-Def 0 is grounded by the module to indicate that the module is present
 - Mod-Def 1 is the clock line of two wire serial interface for serial ID
 - Mod-Def 2 is the data line of two wire serial interface for serial ID
- LOS is an open collector output, which should be pulled up with a 4.7k~10kΩ resistor. Pull up voltage between 2.0V and V_{cc}+0.3V. Logic 1 indicates loss of signal; Logic 0 indicates normal operation. In the low state, the output will be pulled to less than 0.8V.
- RD-/+ : These are the differential receiver outputs. They are internally AC-coupled 100 differential lines which should be

terminated with 100Ω (differential) at the user SERDES.

6) TD-/+ : These are the differential transmitter inputs. They are internally AC-coupled, differential lines with 100Ω differential termination inside the module.

Recommended Interface Circuit

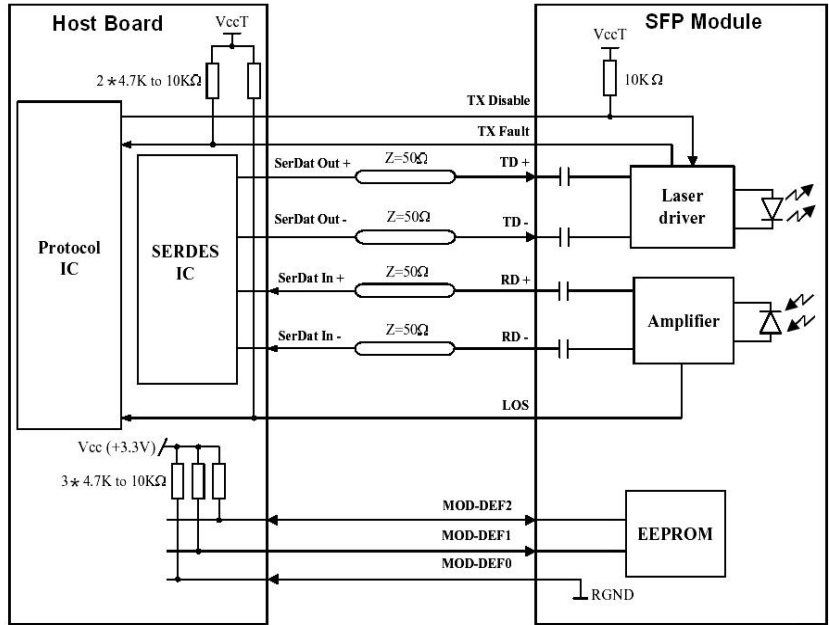

Package Outline

Dimensions are in millimeters. All dimensions are ±0.2mm unless otherwise specified. (Unit: mm)

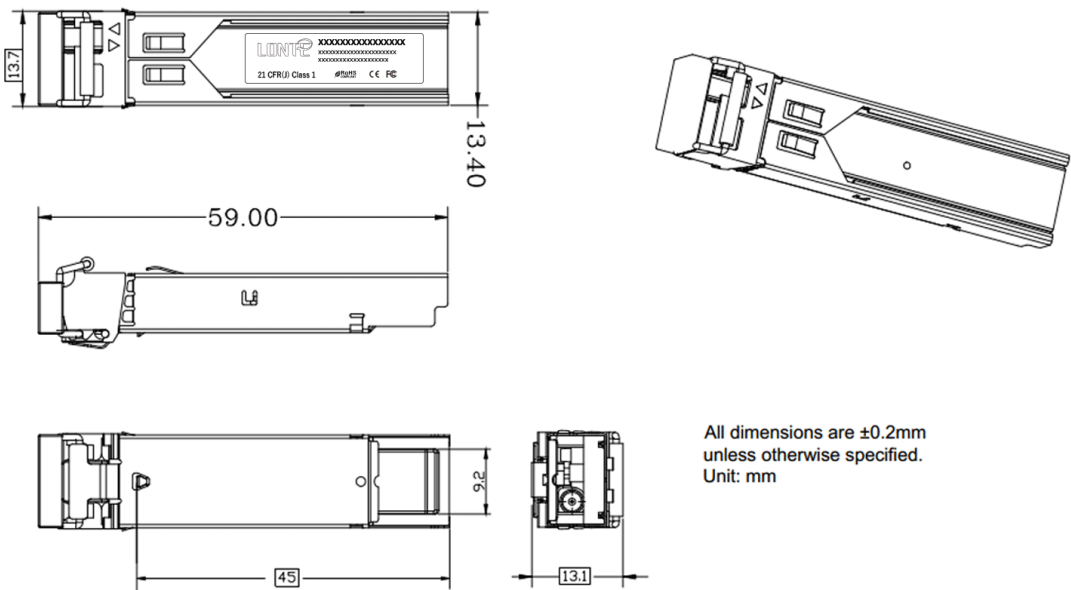

Regulatory Compliance

Feature	Test	Method
Electrostatic Discharge (ESD) to the Electrical Pins	MIL-STD-883E Method 3015.7	Class 1(>1000V for SFI pins, >2000V for other pins.)
Electrostatic Discharge (ESD) Immunity	IEC61000-4-2	Class 2(>4.0kV)
Electromagnetic Interference (EMI)	CISPR22 ITE Class B FCC Class B CENELEC EN55022 VCCI Class 1	Comply with standard
Immunity	IEC61000-4-3	Comply with standard
Eye Safety	FDA 21CFR 1040.10 and 1040.11 EN (IEC) 60825-1,2	Compatible with Class I laser Product

Ordering information

Part. No	Specifications								
	Pack	Rate (Gbps)	Tx (nm)	Po (dBm)	RX	Sen (dBm)	Temp (°C)	Reach (km)	DDM
AC-SFBL-35G1-10	SFP	1.25	1310	-9~-3	PIN	<-20	0~70	10	Y
AC-SFBL-53G1-10	SFP	1.25	1550	-9~-3	PIN	<-20	0~70	10	Y
AC-SFBL-35G1-10F	SFP	1.25	1310	-9~-3	PIN	<-20	-40~85	10	Y
AC-SFBL-53G1-10F	SFP	1.25	1550	-9~-3	PIN	<-20	-40~85	10	Y